

INSTALLATION NOTES:

1. SHIM AS REQUIRED AT EACH INSTALLATION ANCHOR WITH LOAD BEARING SHIM(S). MAXIMUM ALLOWABLE SHIM STACK TO BE ¼ INCH. SHIM WHERE SPACE OF 1/16 OR GREATER OCCURS. SHIM(S) SHALL BE CONSTRUCTED OF HIGH DENSITY PLASTIC OR BETTER.
2. MINIMUM EMBEDMENT AND EDGE DISTANCE EXCLUDE WALL FINISHES, INCLUDING BUT NOT LIMITED TO STUCCO, FOAM, BRICK VENEER AND SIDING.
3. INSTALLATION ANCHORS AND ASSOCIATED HARDWARE MUST BE MADE OF CORROSION RESISTANT MATERIAL OR HAS A CORROSION RESISTANT COATING.
4. INSTALLATION ANCHORS SHALL BE INSTALLED IN ACCORDANCE WITH ANCHOR MANUFACTURER'S INSTALLATION INSTRUCTIONS AND ANCHORS SHALL NOT BE USED IN SUBSTRATES WITH STRENGTHS LESS THAN THE MINIMUM STRENGTH SPECIFIED BY THE ANCHOR MANUFACTURER.
5. INSTALLATION ANCHOR CAPACITIES FOR PRODUCTS HEREIN ARE BASED ON SUBSTRATE MATERIALS WITH THE FOLLOWING PROPERTIES:
 - A. WOOD - MINIMUM SPECIFIC GRAVITY OF 0.55.
 - B. STEEL - MINIMUM 20 GA. STEEL , MINIMUM Fy = 33 KSI.
6. FOR INSTALLATION INTO 2X WOOD BUCK OR FRAMING, USE ONE #8 WOOD SCREW, TYPE INSTALLATION ANCHOR PER LOCATION OF SUFFICIENT LENGTH TO ACHIEVE A MINIMUM 1 1/2" EMBEDMENT AND SHALL MAINTAIN A MIN. EDGE DISTANCE OF 3/4 IN.
7. FOR INSTALLATION THROUGH METAL STUD USE #8 TEK SCREWS OF SUFFICIENT LENGTH TO ACHIEVE 3 THREADS MINIMUM PENETRATION BEYOND METAL STRUCTURE. METAL ANCHORS SHALL MAINTAIN A MINIMUM EDGE DISTANCE OF 3/4 INCH.

GENERAL NOTES:

1. THE PRODUCT SHOWN HEREIN IS DESIGNED AND MANUFACTURED TO COMPLY WITH THE 5TH EDITION 2014 FLORIDA BUILDING CODE(FBC)EXCLUDING HVHZ AND HAS BEEN EVALUATED ACCORDING TO THE FOLLOWING:
 - AAMA/WDMA/CSA 101/1.S.2/A440-08
2. ADEQUACY OF THE EXISTING STRUCTURAL CONCRETE/MASONRY AND 2X FRAMING AS A MAIN WIND FORCE RESISTING SYSTEM CAPABLE OF WITHSTANDING AND TRANSFERRING APPLIED PRODUCT LOADS TO THE FOUNDATION IS THE RESPONSIBILITY OF THE ENGINEER OR ARCHITECT OF RECORD FOR THE PROJECT OF INSTALLATION.
3. 2X BUCKS (WHEN USED) SHALL BE DESIGNED AND ANCHORED TO PROPERLY TRANSFER ALL LOADS TO THE STRUCTURE. BUCK DESIGN AND INSTALLATION IS THE RESPONSIBILITY OF THE ENGINEER OR ARCHITECT OF RECORD FOR THE PROJECT OF INSTALLATION.
4. 2X WOOD STUDS SHALL BE ATTACHED TO FULL LENGTH OF THE FRAME WHEN USED INSIDE METAL FRAMING AS STIFFENERS, WOOD STIFFENERS SHALL BE DESIGNED AND ANCHORED TO PROPERLY TRANSFER ALL LOADS OF THE STRUCTURE. STIFFENER DESIGN AND INSTALLATION IS THE RESPONSIBILITY OF THE ENGINEER OR ARCHITECT OF RECORD FOR THE PROJECT OF INSTALLATION.
5. THE INSTALLATION DETAILS DESCRIBED HEREIN ARE GENERIC AND MAY NOT REFLECT ACTUAL CONDITIONS FOR A SPECIFIC SITE. IF SITE CONDITIONS CAUSE INSTALLATION TO DEVIATE FROM THE REQUIREMENTS DETAILED HEREIN, A LICENSED ENGINEER OR ARCHITECT SHALL PREPARE SITE SPECIFIC DOCUMENTS FOR USE WITH THIS DOCUMENT.
6. APPROVED IMPACT PROTECTIVE SYSTEM IS REQUIRED TO PROTECT THIS PRODUCT IN AREAS REQUIRING IMPACT RESISTANCE.
7. WINDOW FRAME MATERIAL: PVC
8. GLASS MEETS REQUIREMENTS OF ASTM E1300-04 GLASS CHARTS.
9. DESIGNATIONS:
O: FIXED PANEL

CROFT, LLC

SERIES 21 FIXED PICTURE WINDOW

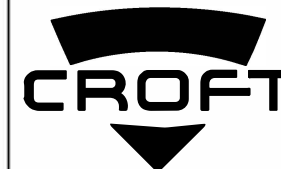
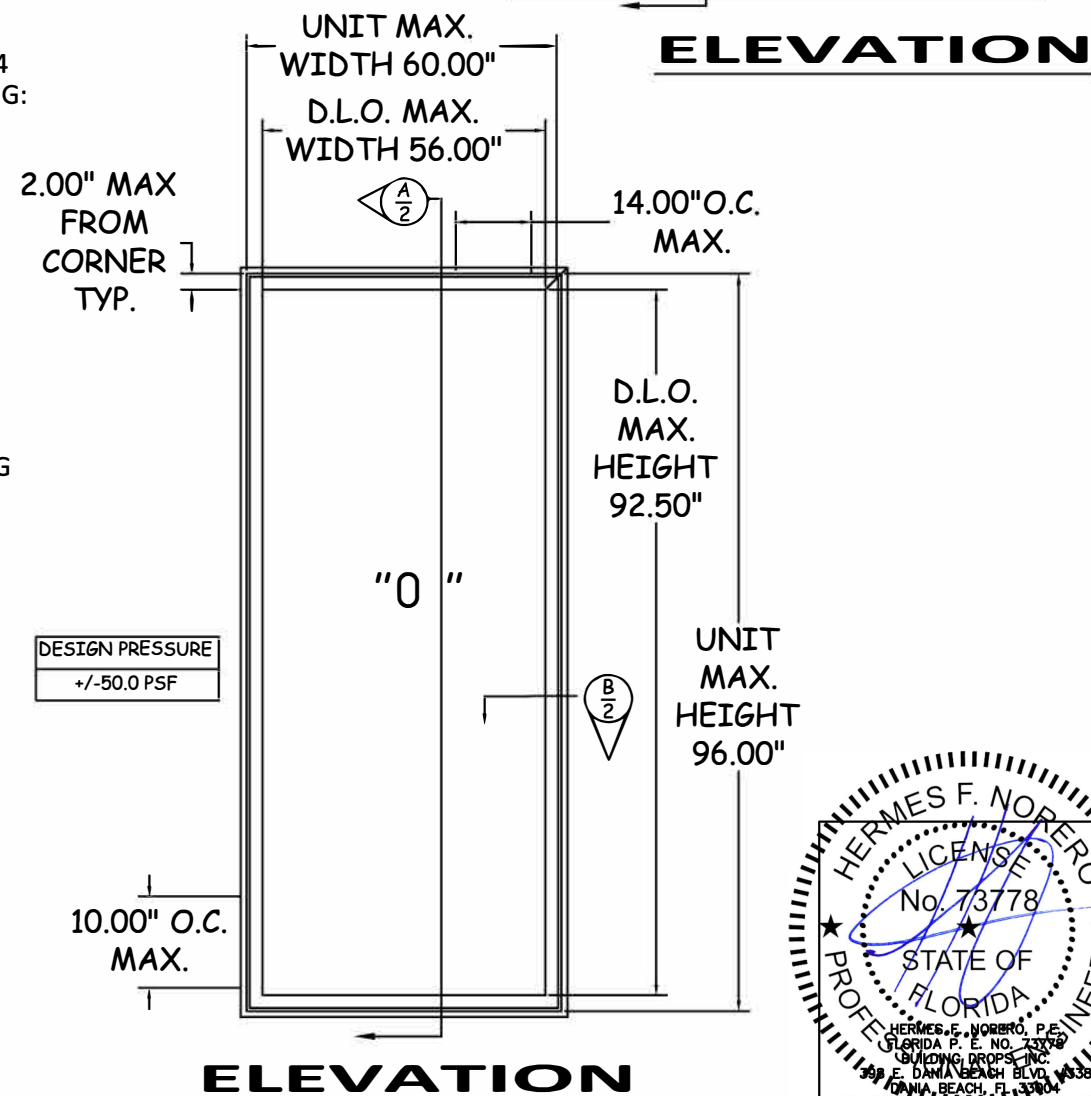
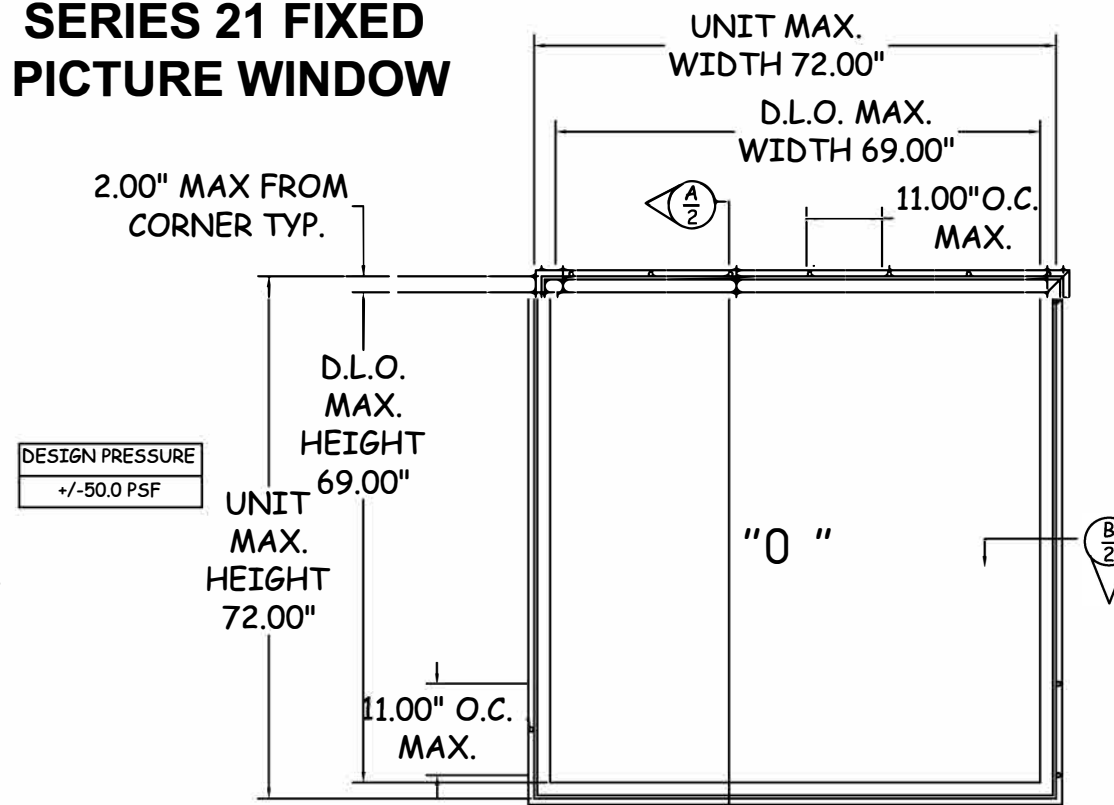

Title: **SERIES 21 FIXED PICTURE WINDOW**

NOTES AND ELEVATION
CROFT, LLC.
 P.O. BOX 826
 McCOMB, MS. 39649
 PH: 601-684-6121 FX: 601-783-3188

REVISIONS		NO	DESCRIPTION	BY	DATE
A.	5TH EDITION 2014 FBC REVISION	LS	2/11/16		

11/14/12	DWN BY: J.BITZ	CHK BY: --	SCALE: NONE
DRAWING #: 0020-952			
SHEET: 1 OF 2			

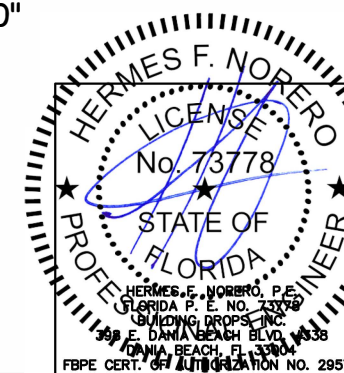

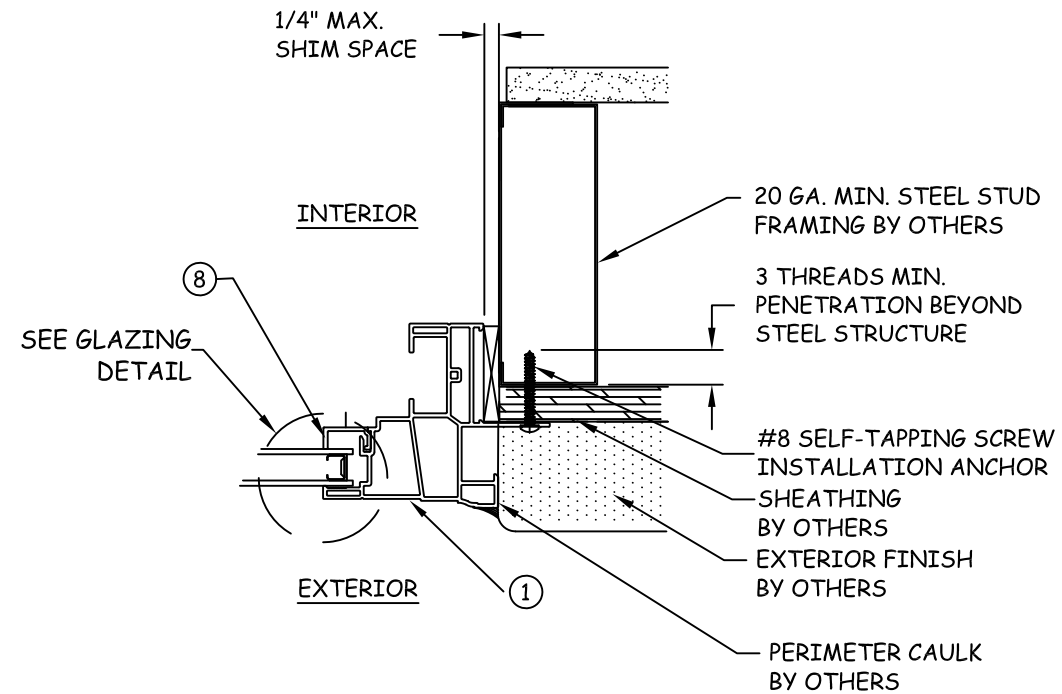
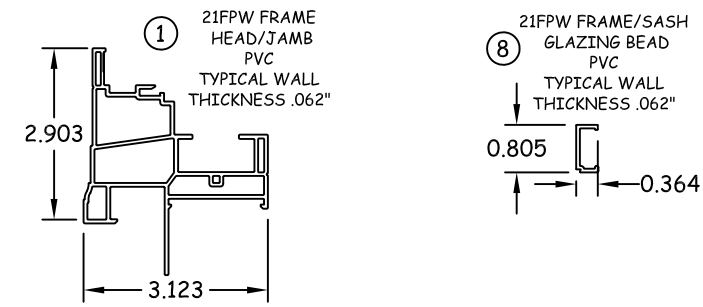
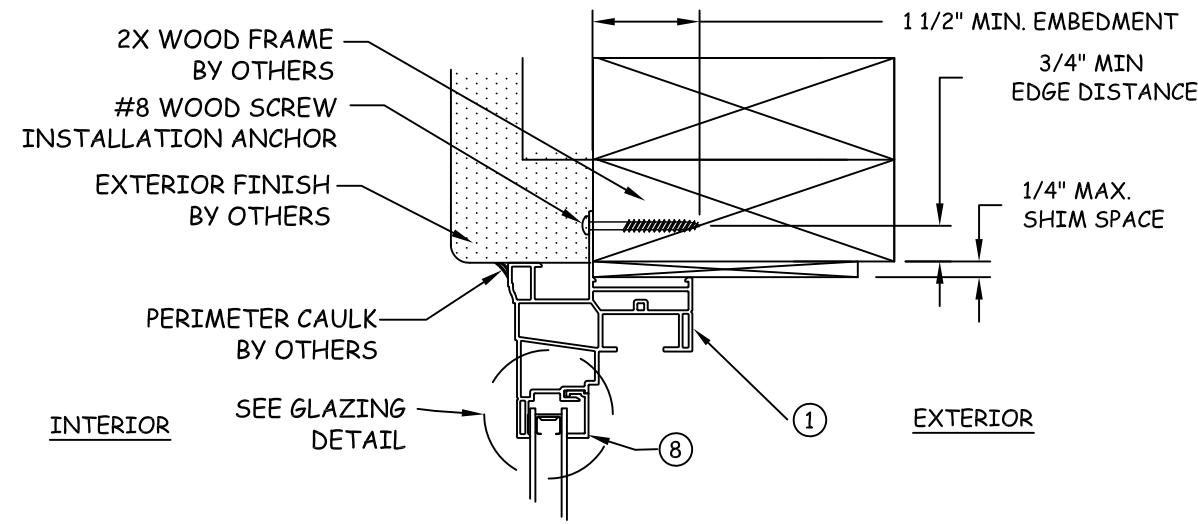

B
2 **HORIZONTAL SECTION**
JAMB - STEEL STUD FRAME
NAIL FIN

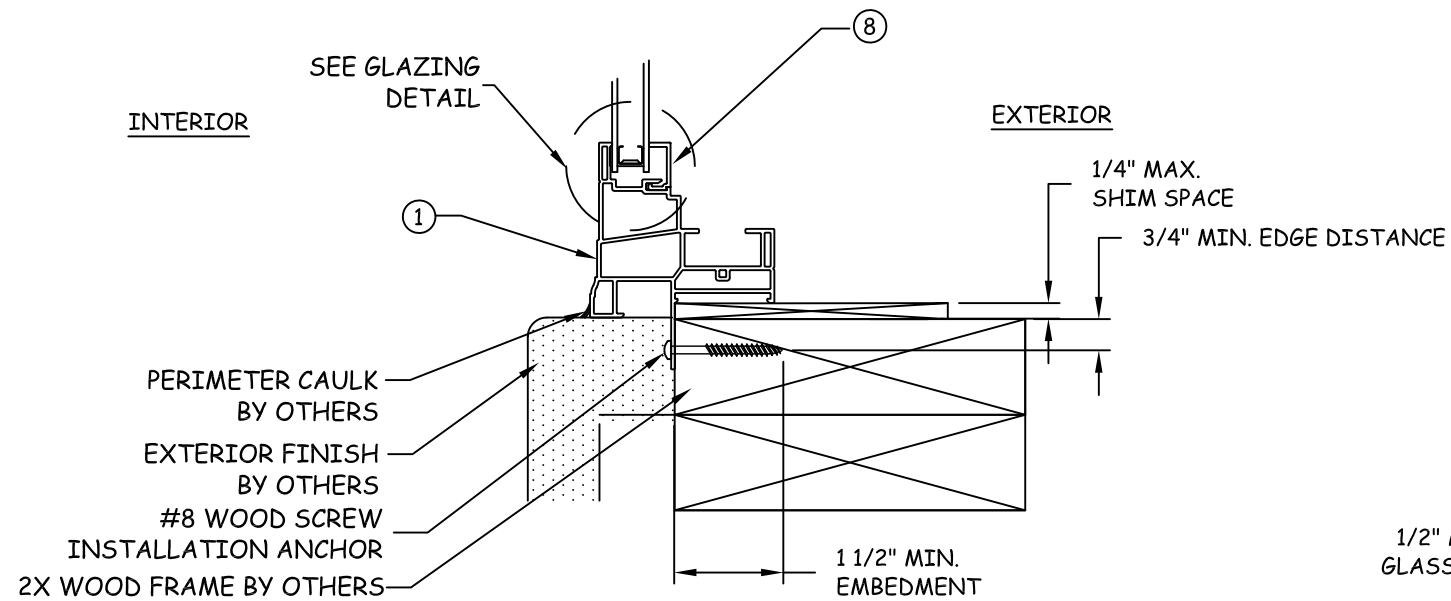

A
2 **VERTICAL SECTION**
SILL - 2X WOOD FRAME
NAIL FIN

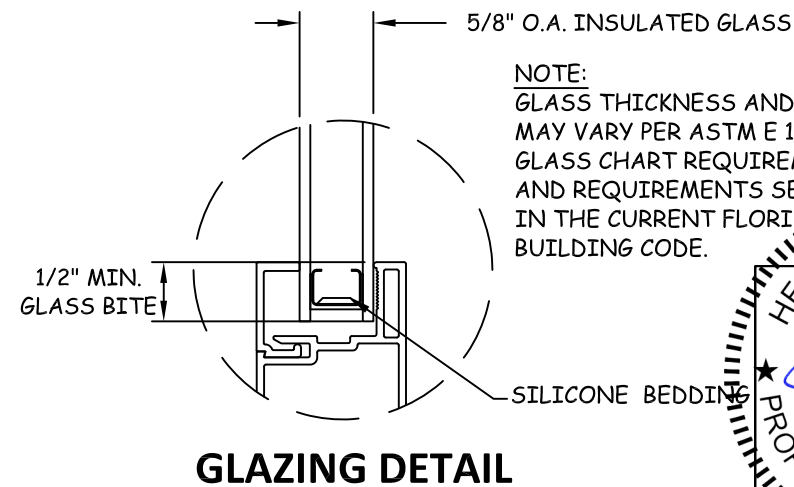

GLAZING DETAIL

Title: **SERIES 21 FIXED PICTURE WINDOW**

X-SECTIONS & GLAZING DETAIL

CROFT, LLC.
P.O. BOX 826
McCOMB, MS. 39649
PH: 601-684-6121 FX: 601-783-3188

NO.	DESCRIPTION	BY	DATE

11/19/12	DWN BY: J. BITZ	CHK BY: -	SCALE: NONE
----------	-----------------	-----------	-------------

DRAWING #: **0020-952**

SHEET: **2 OF 2**

